

Installation and Operating Manual for Components

# HSV<sup>®</sup>-S-Q HSV<sup>®</sup>-M-Q

Safety Valve Interlock for Lever-Operated Valves

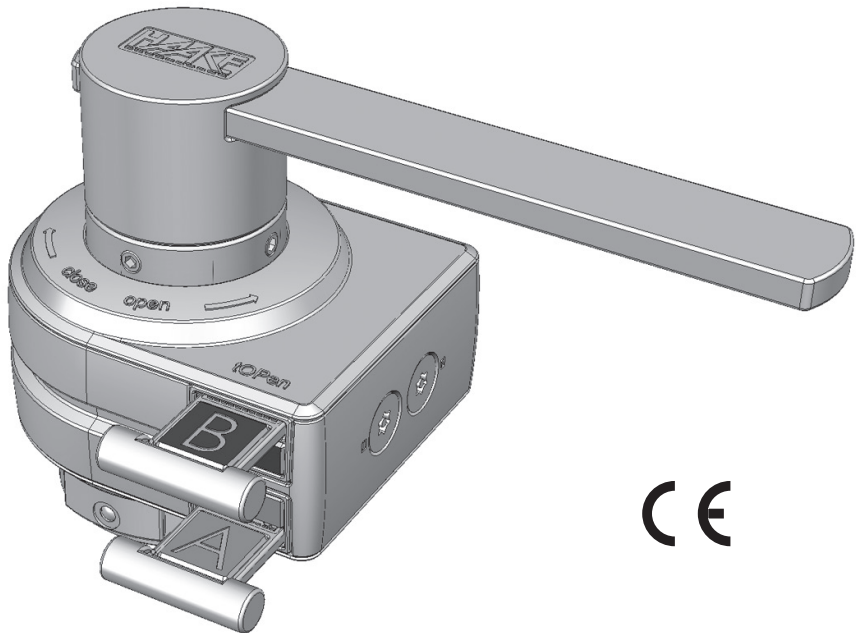

CE

**HAKE<sup>®</sup>**

This installation and operating manual contains proprietary information which is subject to copyright. No parts of this documentation may be reproduced or transferred in any manner or by any means, be it electronic or mechanical, for any purpose without obtaining prior written consent.

Haake Technik GmbH assumes no liability for damage or subsequent damage, arising from the use of components or replacement parts which are not original parts.

Haake and HSV are registered trademarks of Haake Technik GmbH. All other brand and product names not mentioned here are or may be registered trademarks and are to be treated accordingly.

Issue 3, July 2011 (Translation of Original Manual)

© Haake Technik GmbH, Master Esch 72, 48691 Vreden, Germany

All rights reserved.

## Contents

Scope	3
Intended use	3
Foreseeable misuse	3
Identification	4
Safety-related functioning	4
Defects which cannot occur	5
Scope of delivery	6
Structure and function	6
Safety measures	7
Installation	8
Performance check	13
Operation	13
Maintenance	14
Disassembly	14
Troubleshooting	15
Technical data	16
Dimensions	17
EC Declaration of Conformity	18

### **Attention!**

Warnings are indicated in the relevant sections by a box labelled **Attention!**

## 1 Scope

This installation and operating manual is intended for persons who have been authorised to carry out tasks involving the installation or operation of the HSV valve interlock. International, national and, where appropriate, regional regulations are to be observed when handling valves. This installation and operating manual is applicable to the models

- HSV-M-Q
- HSV-S-Q

If you have any questions which are not answered in this manual, please get in touch with your regional customer service centre or else make direct contact with

### **Haake Technik GmbH**

Master Esch 72, 48691 Vreden, Germany

Telephone +49 2564 39650

Fax +49 2564 396590

Info@haake-technik.com

## 2 Intended use

This valve interlock serves the purpose of locking lever-operated valves such as ball valves, butterfly valves or plug valves. The valve can be locked in either end position and it will then release the respective key. This valve interlock may be utilised indoors or outdoors. The valve interlock must only be installed in accordance with the key interlock sequence plan of the interlock system. Other applications are prohibited.

Incorrect use for instance includes under water application areas or direct connection with electrically driven valves.

## 3 Foreseeable misuse

Do not use an extension for the lever. Do not attempt to use any other object other than the assigned key to unlock the valve interlock. Do not attempt to insert or remove a key by applying excessive force or with the aid of a tool (hammer).

## 4 Identification

Precise identification of the valve interlock is provided by the model designation and serial number on the name plate located on the underside of the housing. Note these details (prior to installation, if necessary), so that they can be provided in case of questions or for ordering spare parts.

The name plate also indicates the valve designation for which the valve interlock is intended. These details can be obtained from the key interlock sequence plan with the exception of the serial number if the component is part of a system.

## 5 Safety-related functioning

The safety-related function is performed according to the following requirements:

- Interlocking of an adapter in an end position up to a certain force; open or closed.
- Interlocking (trapping) of the key which belongs to the other end position
- Release for operation of the lever through insertion of an additional coded key.
- Interlocking of both keys, provided the lever is not positioned in an end position.
- Release of the key which belongs to the other end position, if the lever is positioned in an assigned end position.

## 6 Defects which cannot occur

Defects which cannot occur are outlined in the table. These have been eliminated due to the design and selection of materials for the component:

Potential Defect	Elimination of Defect	Limitations of Use	Explanation
Wear, corrosion	Permissible acc. to tables A.4 and A.5 of DIN EN ISO 13849-2	See sections <b>Intended use</b> on page 3 and <b>Technical data</b> on page 16	Application of carefully selected materials and manufacturing processes; use of proven springs and special mounting methods
Non-tightening/Loosening	Permissible acc. to tables A.4 and A.5 of DIN EN ISO 13849-2	See section <b>Intended use</b> on page 3	Application of carefully selected safety controls and treatment procedures; use of proven springs and special mounting methods
Weakening of force due to permanent deformation or fracture	Permissible acc. to table A.5 of DIN EN ISO 13849-2	See section <b>Operation</b> on page 13	Use of proven springs and special mounting methods
Fracture, deformation due to excessive load	Permissible acc. to tables A.4 and A.5 of DIN EN ISO 13849-2	See section <b>Operation</b> on page 13	Application of carefully selected materials; over-dimensioning using safety factor 2 and replication of parts; use of proven springs and special mounting methods
Stiffness/Getting caught	Permissible acc. to tables A.4 and A.5 of DIN EN ISO 13849-2	See sections <b>Intended use</b> on page 3 and <b>Operation</b> on page 13	Application of carefully selected materials and lubrication. Careful selection, combination, arrangement, assembly and installation of components. Over-dimensioning using safety factor 2

## 7 Scope of delivery

- 1 Interlock base body  
(HSV-M-Q or HSV-S-Q)
- 1 Adapter
- 1 Torque support
- 1 Lever assembly
- 1 or 2 HSV-K key(s)  
Fixing material

**Please note:**

Corresponding HSV-K keys are separate components.

## 8 Structure and function

The valve interlock consists of a base body (housing), a lever, an adapter, a torque support and one or two keys. The adapter and the torque support are the connection to the valve. The lever can be used to operate the valve once released. The housing has two key shafts. The valve cannot be operated unless both keys are inserted in the interlock. Both keys remain locked in the interlock when the valve is in operation.

The corresponding key can only be removed once the valve has reached an end position. The other key remains locked in the interlock. The valve is opened if the upper key has been removed. If the lower key has been removed, the valve is closed.

The keys are labelled with coloured markings and can be inserted from either side into the appropriate key shafts. Individual keys may already be inserted and locked in other components of the interlock system upon delivery.

## 9 Safety measures

### 9.1 Organisational measures

Persons who have been authorised to carry out tasks involving the installation or removal of the valve interlock must have read and understood this manual prior to commencing such tasks.

The owner of the installation or machine has to ensure that a safe and secure procedure takes place when the valve interlock is installed or removed, by implementing suitable measures.

### 9.2 Safety of persons

Personnel responsible for installation or removal tasks have to be suitably skilled or else have to be instructed by suitably skilled persons. On account of their technical training and experience, such skilled persons have sufficient knowledge of the machine or system. These persons are sufficiently familiar with the applicable domestic work protection and accident prevention regulations of relevance here, that they are able to assess the operational safety of the system or machine.

It is necessary to implement accident- and fall-prevention measures, whenever tasks are performed or areas are traversed at height.

### 9.3 Operating conditions and limitations of use

Comply with the operating conditions and technical data described in this manual.

### 9.4 Assembly/Disassembly

Check the name plate to make sure that the valve interlock is appropriate and intended for use with the valve prior to commencing installation tasks.

It is necessary to actuate the valve during its installation. Take appropriate measures to ensure that there is no hazard posed by this process. It may be necessary to inform other persons and to obtain permission to actuate the valve.

Only use the lever supplied with the valve interlock. Do not attach another control element.

### 9.5 Repairs

Do not carry out any repairs on the valve interlock. Do not replace or exchange any parts. For repair of a damaged or defective valve interlock, send it to Haake Technik GmbH.

Do not make any changes to the valve interlock or its components. Severe malfunctions may occur otherwise, which could result in serious injury to personnel and permanent damage to property.

## 10 Installation

### 10.1 Preparation

The following tools are required for installation of the valve interlock:

- Allen key, 3 mm
- Allen key, 4 mm
- Machinist's hammer, 250 g
- Drift punch, 5 mm
- Tool to remove lever from valve
- Screwlock (for example: Loctite)

Check the name plate and the key interlock sequence plan to make sure that the valve interlock is appropriate and intended for use with the valve prior to commencing installation tasks.

Clean the work environment by removing dirt, grease and oil.

### 10.2 General approach

Only use precisely fitting tools (spanners) for removing and tightening bolts and nuts. Otherwise bolts and nuts may become damaged and unusable.

Observe the acceptable tightening torques:

M4: 2.5 Nm

M5: 4 Nm

M6: 7 Nm

M8: 18 Nm

M10: 35 Nm

Use appropriate means to secure all threaded fittings, for example, Loctite. For application procedures follow the instructions of the corresponding manufacturer.



### 10.3 Installation on valve with ISO flange

Prior to removing the lever, check the position of the valve (opened or closed).

Turn the hollow shaft of the valve interlock towards the same position (opened => turn anti-clockwise right up to the stop; closed => turn clockwise right up to the stop).

Remove the standard lever fitted to the valve and all associated bolts, nuts and washers.

Align the ISO shell of the valve interlock with the valve flange and, depending on the number of holes in the valve flange, use four or two countersunk screws to secure the shell.

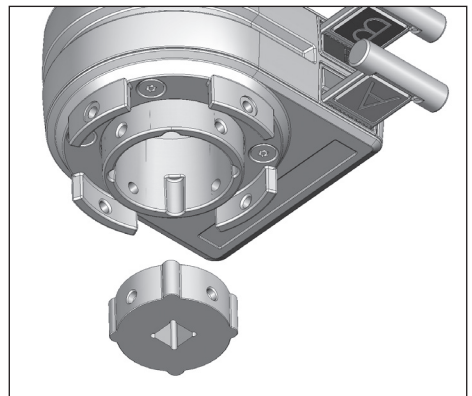
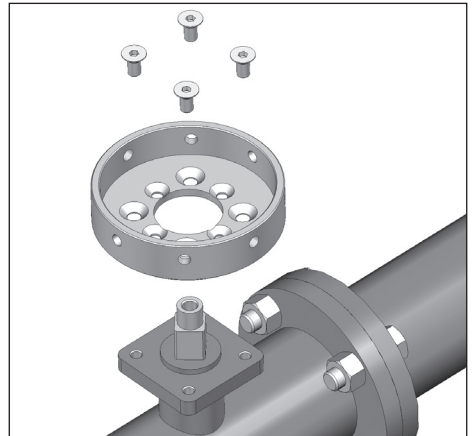
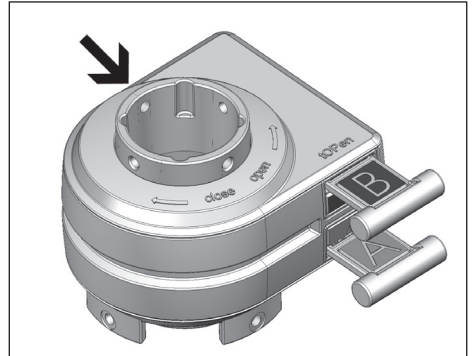

Fit the adapter in the valve interlock. By inserting the Allen key through the holes in the housing tighten the adapter with four threaded pins.

Align the valve interlock so that the keys can be easily reached; four positions are possible.

Fit the valve interlock on the ISO shell and punch in the four slotted pins to secure the assembly. **Avoid damaging the valve with the hammer.**

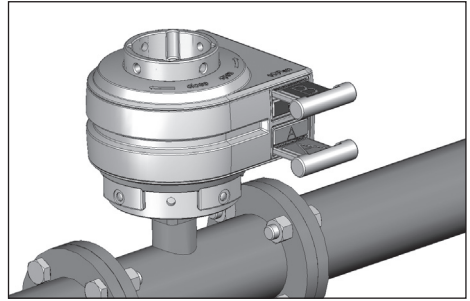

Fit the lever of the valve interlock on the shaft according to the valve position (parallel or crosswise to line).

Tighten the lever with four threaded pins.

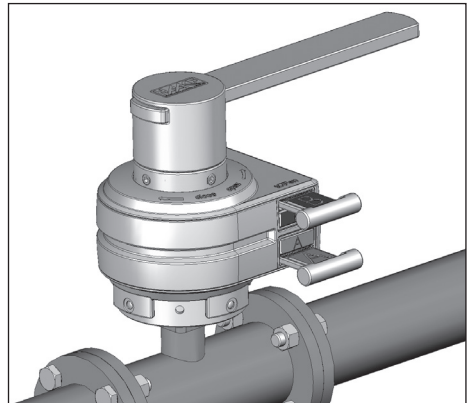

## 10.4 Installation on valve without ISO flange

Prior to removing the lever, check the position of the valve (opened or closed).

Turn the hollow shaft of the valve interlock towards the same position (opened => turn anti-clockwise right up to the stop; closed => turn clockwise right up to the stop).

Remove the standard lever fitted to the valve and all associated bolts, nuts and washers.

Position the adapter on the valve spindle. Keep in mind that the holes in the adapter are located on the valve side (smaller edge distance).

Use an appropriate washer and a nut to secure the adapter. You can use the original nut of the lever, unless it is damaged.

Screw the four threaded pins into the housing of the valve interlock until they are flush against the inside.

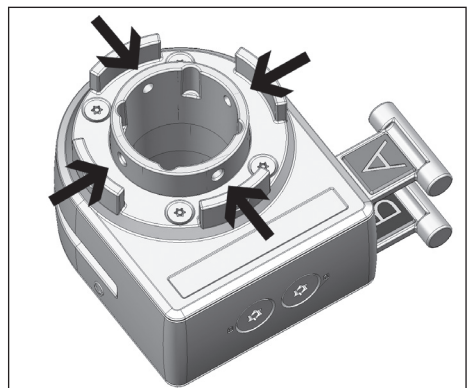
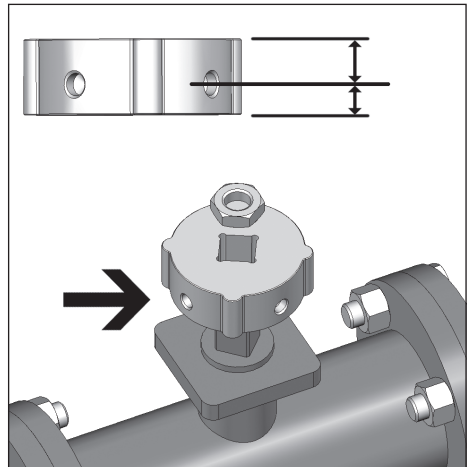
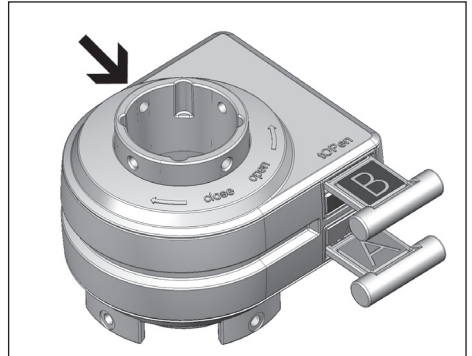

Align the valve interlock above the line so that the keys can be easily reached; four positions are possible.

Insert the torque support into the valve lock, so that it can be guided above the line later on. Punch in four slotted pins to secure the assembly. **Avoid damaging the valve with the hammer.**

Then fit the valve interlock with torque support on the adapter.

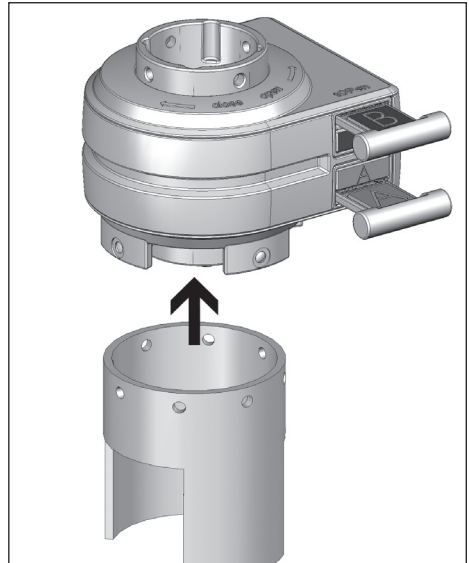

Fit the lever of the valve interlock on the shaft according to the valve position (parallel or crosswise to line). Tighten the lever with four threaded pins.

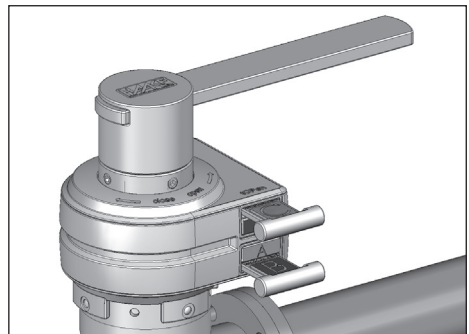

Turn the lever through 45° and by guiding the Allen key through the holes in the torque support, tighten the four already fitted threaded pins to secure the valve interlock at the adapter.

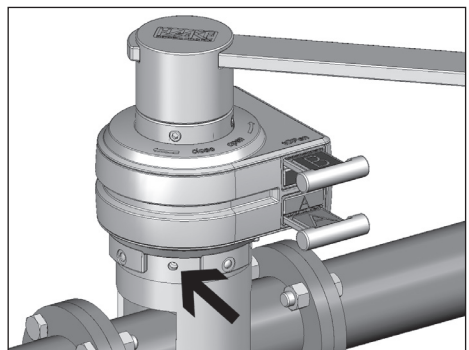

## 11 Performance check

### Attention!

The protective effectiveness of the valve interlock is to be checked regularly within the scope of and in accordance with the German Ordinance on Industrial Safety and Health (Betriebssicherheitsverordnung).

Once installed, do not loosen any bolts or nuts or remove any pins; otherwise, the effectiveness of the safety-related functions is no longer guaranteed.

Once installation is complete, carry out the following inspections:

- Check all bolted connections for tightness and ensure that the bolts cannot come loose by themselves.
- Check whether the key(s) can be easily inserted and whether the key(s) only fit in one given shaft.
- Insert both keys and check the valve for ease of movement.
- Remove a key and check whether valve actuation is blocked. Re-insert the key.
- Put the lever in the other end position, remove the other key, and check whether valve actuation is blocked. Re-insert the key.
- Record the results of the performance check.

## 12 Operation

### Attention!

Do not ever attempt to disengage the interlock in a locked state with an extended arm of a lever. This may destroy the inner components and disable the safety function.

Do not ever attempt to insert or remove a key by applying excessive force or with the aid of a tool (hammer).

Only actuate the valve if both keys have been completely inserted.

If the valve is closed, you can remove the lower key and if the valve is opened, the upper key can be removed.

- Insert the appropriate key into the open key shaft. The interlock is disengaged and the key is locked in the key shaft.
- Turn the valve lever all the way to the other end position (open or close).
- Remove the other key from the valve interlock. Now the valve is locked and can no longer be actuated.

## 13 Maintenance

The valve interlock requires little maintenance and has been lubricated for life.

### Attention!

Adapt the frequency of checks to the environmental conditions at the application site.

We recommend introducing the following measures within the scope of preventative maintenance:

- Check the valve interlock at regular intervals (at least once a year) for external damage.
- Clean a soiled valve interlock using neutral soap suds and a cloth.
- Check for signs of corrosion and check the valve interlock for proper working order as needed.

## 14 Disassembly

Disassembly procedures depend on the conditions at the site. Observe the following essential instructions:

Only use precisely fitting tools (spanners) for removing and tightening bolts and nuts. Otherwise bolts and nuts may become damaged and unusable.

With the torque support mounted, turn the lever through 45° in order to reach the bolts in the adapter.

Drive out the four slotted pins using a 5 mm drift punch. **Avoid damaging the valve with the hammer.**

Carefully loosen all bolts/screws. It may be necessary to drill out stuck bolts/screws.

Only remove the complete valve interlock assembly and then install a standard lever. Do not dismantle the valve interlock assembly on your own.

## 15 Troubleshooting

Fault	Possible cause	Remedy
You cannot remove the key.	End position not reached.	Ensure that the lever is in end position. The lever must be positioned parallel to the housing edge.
	The other key is not completely inserted.	Insert the other key right up to the stop.
You cannot insert the key.	Wrong key.	Check identification of key and key shaft.
	Foreign matter in the key shaft.	Carefully remove foreign matter. If this is not possible, contact Haake Technik.
	Formation of ice.	Slightly warm up the valve interlock. <b>Do not use excessive heat!</b>
	Deformed key.	Check key. Contact Haake Technik in case of deformation.
Unable to install the valve interlock.	Wrong position.	Check valve and name plate against key interlock sequence plan.
	Faulty valve information (for example: new version).	Contact Haake Technik.
Unable to remove the valve interlock.	Screws/Bolts secured very firmly.	Contact Haake Technik.
Valve interlock does not disengage.	Lock lever not unhooked.	Turn lever in both directions.
	Key has not been correctly inserted.	Insert key right up to the stop.
Logic circuit not safe.		Check key interlock sequence plan; check installation; contact Haake Technik.
Valve can only be actuated with great difficulty.	Valve does not move smoothly.	Remove valve interlock and actuate the valve. Lubricate the valve if necessary.
	Valve interlock does not move smoothly.	Contact Haake Technik.
Lost keys.		Contact Haake Technik.

## 16 Technical data

Material	316 stainless steel
Ambient temperature	-40 to +80 °C
Application areas	Water supply networks, power plants, oil and gas networks, tank farms, bottling plants, paper mills
Application environment	Outside/Inside
Ambient atmosphere	Industrial environment
Vibration resistance	150 Hz max.
Impact resistance	30 g max.
Mechanical life	10,000 actuations MTTFd 150 years
Service life	30 years
Position of use/installation	Horizontal/Vertical
Fastening	On valve drive element and valve flange if applicable
Weight	HSV-M-Q: 6 to 8 kg (dependent on lever and torque support) HSV-S-Q: 3 to 5 kg (dependent on lever and torque support)
Holding force	HSV-M-Q: 250 Nm HSV-S-Q: 125 Nm
Year of manufacture	2011



# 17 Dimensions

## HSV-S-Q

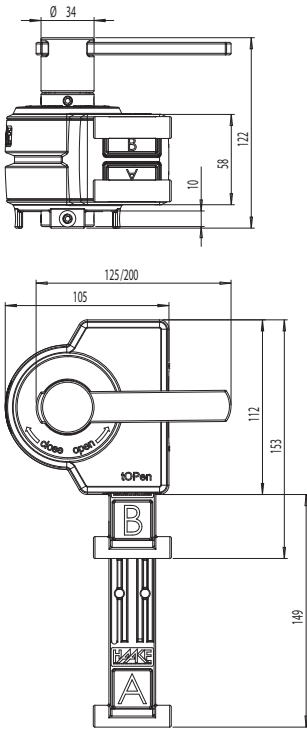

## HSV-M-Q

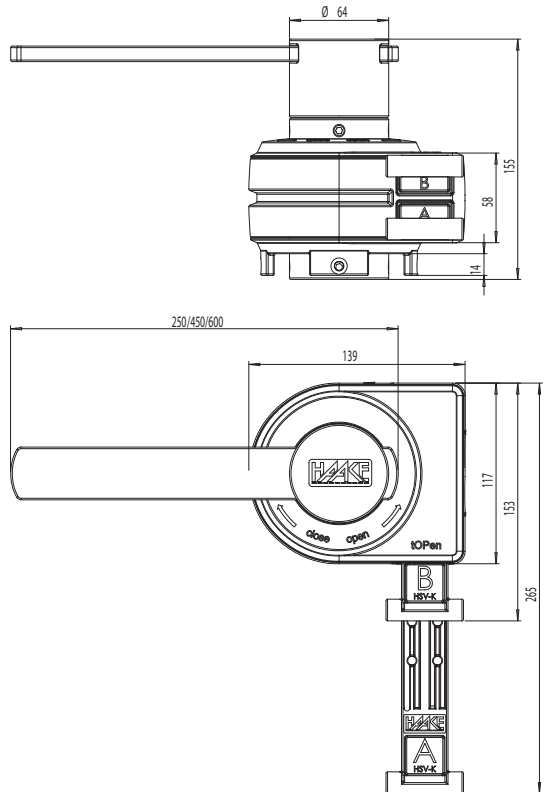

Dimensional specifications in mm.

# 18 EC Declaration of Conformity



## EC Declaration of Conformity in accordance with EC Directive 2006/42/EC, Annex II 1. A

The company **Haake Technik GmbH**  
**Master Esch 72**  
**48691 Vreden, Germany**

hereby declares that the valve locking systems of the series:

**HSV**

Type: **See appendix**

in their delivered form comply with the following relevant provisions:

EC Directive: **Machinery Directive 2006/42/EC**

Test specification: **GS-ET 31: 2010-02**  
**Principles for the assessment and certification of**  
**locking devices with key transfer systems**  
(guide)

Each valve locking system consists of at least two locking components. The system can be extended to include a key change station. Valve locking systems use coded keys, which ensure that valves are activated according to a given sequence.

Our quality management system guarantees that all components of the series are manufactured to the same quality. Consequently, the issued declaration of conformity applies to all products listed in the appendix at all times starting with serial no. 1131763.

The conformity assessment procedure described in Annex X of the afore mentioned EC directive has been selected for the products. The following notified body is responsible for assessment, authorisation and monitoring:

Fachausschuss Elektrotechnik  
Prüf- und Zertifizierungsstelle im BG-PRÜFZERT  
Gustav-Heinemann-Ufer 130  
D-50968 Köln, Germany

Identification number: 0340

The authorised representative responsible for the compilation of the technical documents is:

HAAKE Technik GmbH  
Herr Jens Schoppen  
Master Esch 72  
D-48691 Vreden, Germany

Vreden, 02.08.11

André Haake  
(Managing director)

Haake Technik GmbH  
Master Esch 72  
D-48691 Vreden, Germany

Tel. +49-2564-3965-0  
Fax +49-2564-3965-90

www.haake-technik.com  
info@haake-technik.com

V1.3

Declaration of Conformity HSV in accordance with EC Directive 2006\_42, Rev. B, JSO, 02.08.11 - A.Haake.doc Page 1 of 2

blank page

