

Installation and Operating Manual for Components

HSV[®]-S-R HSV[®]-M-R HSV[®]-L-R

Safety Valve Interlock for Handwheel Operated Valves

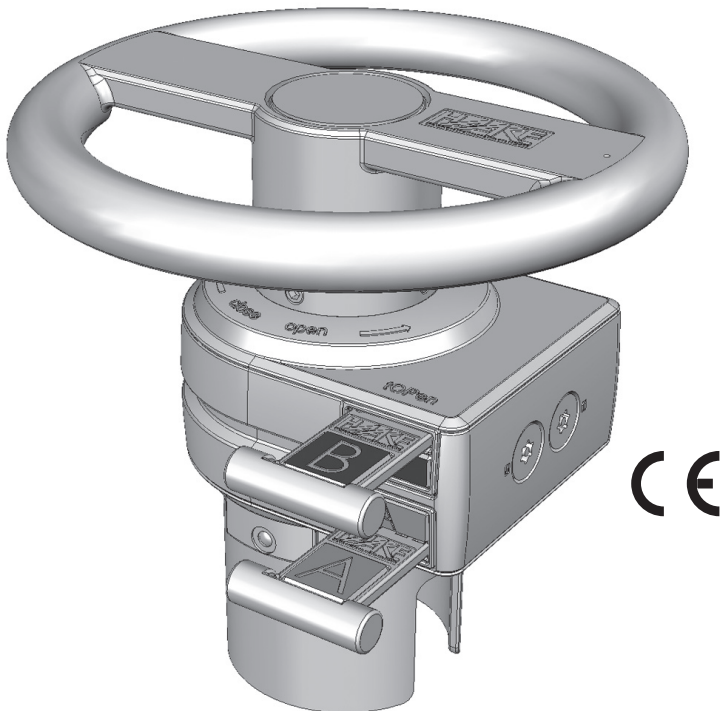

HAKE[®]

This installation and operating manual contains proprietary information which is subject to copyright. No parts of this documentation may be reproduced or transferred in any manner or by any means, be it electronic or mechanical, for any purpose without obtaining prior written consent.

Haake Technik GmbH assumes no liability for damage or subsequent damage, arising from the use of components or replacement parts which are not original parts.

Haake and HSV are registered trademarks of Haake Technik GmbH. All other brand and product names not mentioned here are or may be registered trademarks and are to be treated accordingly.

Issue 3, November 2010 (Translation of Original Manual)

© Haake Technik GmbH, Master Esch 72, 48691 Vreden, Germany.

All rights reserved.

Contents

Scope	3
Intended use	3
Foreseeable misuse	3
Identification	4
Safety-related functioning	4
Defects which cannot occur	5
Scope of delivery	6
Structure and function	6
Safety measures	7
Installation	8
Performance check	15
Operation	15
Maintenance	16
Disassembly	17
Troubleshooting	18
Technical data	20
Dimensions	21
EC Declaration of Conformity	23

Attention!

Warnings are indicated in the relevant sections by a box labelled **Attention!**.

1 Scope

This installation and operating manual is intended for persons who have been authorised to carry out tasks involving the installation or operation of the HSV valve interlock. International, national and, where appropriate, regional regulations are to be observed when handling valves. This installation and operating manual is applicable to the models

- HSV-S-R
- HSV-M-R
- HSV-L-R

If you have any questions which are not answered in this manual, please get in touch with your regional customer service centre or else make direct contact with

Haake Technik GmbH

Master Esch 72, 48691 Vreden, Germany

Telephone +49 2564 39650

Fax +49 2564 396590

Info@haake-technik.com

2 Intended use

This valve interlock serves the purpose of locking handwheel-operated valves such as slide valves, cone valves, or gearboxes. The valve can be locked in either end position and it will then release the respective key. This valve interlock may be utilized indoors or outdoors. The valve interlock must only be installed in accordance with the key interlock sequence plan of the interlock system. Other applications are prohibited.

Incorrect use for instance includes under water application areas or direct connection with electrically driven valves.

3 Foreseeable misuse

Only use the handwheel for operating the valve. Do not attempt to use any other object other than the assigned key to unlock the valve interlock. Do not attempt to insert or remove a key by applying excessive force or with the aid of a tool (hammer).

4 Identification

Precise identification of the valve interlock is provided by the model designation and serial number on the name plate located on the underside of the housing. Note these details (prior to installation, if necessary), so that they can be provided in case of questions or for ordering spare parts.

The name plate also indicates the valve designation for which the valve interlock is intended. These details can be obtained from the key interlock sequence plan with the exception of the serial number if the component is part of a system.

5 Safety-related functioning

The safety-related function is performed according to the following requirements:

- Interlocking of an adapter in an end position up to a certain force; open or closed.
- Interlocking (catching) of the key which belongs to the other end position
- Release for operation of the handwheel through insertion of both coded keys.
- Interlocking of both keys, provided the adapted valve is not positioned in an end position that is to be defined during installation.
- Release of the key which belongs to the other end position, if the adapted valve is positioned in an assigned end position.

6 Defects which cannot occur

Defects which cannot occur are outlined in the table. These have been eliminated due to the design and selection of materials and components.

Potential Defect	Elimination of Defect	Limitations of Use	Reason
Wear, corrosion	Permissible acc. to tables A.4 and A.5 of DIN EN ISO 13849-2	See sections Intended use on page 3 and Technical data on page 20	Application of carefully selected materials and manufacturing processes; use of proven springs and special mounting methods
Non-tightening/Loosening	Permissible acc. to tables A.4 and A.5 of DIN EN ISO 13849-2	See section Intended use on page 3	Application of carefully selected safety controls and treatment procedures; use of proven springs and special mounting methods
Weakening of force due to remaining deformation or fracture	Permissible acc. to table A.5 of DIN EN ISO 13849-2	See section Operation on page 15	Use of proven spring and special mounting methods
Fracture, deformation due excessive load	Permissible acc. to tables A.4 and A. 5 of DIN EN ISO 13849-2	See section Operation on page 15	Application of carefully selected materials; over-dimensioning using safety factor 2 and replication of parts; use of proven springs and special mounting methods
Stiffness/Getting caught	Permissible acc. to tables A.4 and A. 5 of DIN EN ISO 13849-2	See sections Intended use on page 3 and Operation on page 15	Application of carefully selected materials und lubrication. Careful selection, combination, arrangement, assembly and installation of components. Over-dimensioning using safety factor 2

7 Scope of delivery

- 1 Interlock base body
(HSV-S-R, HSV-M-R or HSV-L-R)
- 1 Adapter
- 1 Torque support
- 1 Handwheel assembly
- 1 or 2 HSV-K key(s)
Fixing material

Please note:

Corresponding HSV-K keys are separate components.

8 Structure and function

The valve interlock consists of a base body (housing), a handwheel, an adapter, a torque support and one or two keys. The adapter and the torque support are the connection to the valve. The handwheel can be used to operate the valve once released. The housing has two key shafts. The valve cannot be operated unless both keys are inserted in the interlock. Both keys remain locked in the interlock when the valve is in operation.

The corresponding key can only be removed once the valve has reached an end position. The other key remains locked in the interlock. The valve is opened if the upper key has been removed. If the lower key has been removed, the valve is closed.

The keys are labelled with coloured markings and can be inserted from either side into the appropriate key shafts. Individual keys may already be inserted and locked in other components of the interlock system upon delivery.

9 Safety measures

9.1 Organisational measures

Persons who have been authorised to carry out tasks involving the installation or removal of the valve interlock must have read and understood this manual prior to commencing such tasks.

The owner of the installation or machine has to ensure that a safe and secure procedure takes place when the valve interlock is installed or removed, by implementing suitable measures.

9.2 Safety of persons

Personnel responsible for installation or removal tasks have to be suitably skilled or else have to be instructed by suitably skilled persons. On account of their technical training and experience, such skilled persons have sufficient knowledge of the installation or machine. These persons are sufficiently familiar with the applicable domestic work protection and accident prevention regulations of relevance here, that they are able to assess the operational safety of the installation or machine.

It is necessary to implement accident- and fall-prevention measures, whenever tasks are performed or areas are traversed at height.

9.3 Operating conditions and limitations of use

Comply with the operating conditions and technical data described in this manual.

9.4 Assembly/Disassembly

Check the name plate to make sure that the valve interlock is appropriate and intended for use with the valve prior to commencing installation tasks.

It is necessary to actuate the valve during its installation. Take appropriate measures to ensure that there is no hazard posed by this process. It may be necessary to inform other persons and to obtain permission to actuate the valve.

Only use the handwheel supplied with the valve interlock or the original handwheel of the valve. Do not attach another control element.

9.5 Repairs

Do not carry out any repairs on the valve interlock. Do not replace or exchange any parts. For repair of a damaged or defective valve interlock, send it to Haake Technik GmbH.

Do not make any changes to the valve interlock or its components. Severe malfunctions may occur otherwise, which could result in serious injury to personnel and permanent damage to property.

10 Installation

10.1 Preparation

The following tools are required for installation of the valve interlock:

- Allen keys, 2 mm, 3 mm, 4 mm
- Torx-TR keys (Tx 30, Tx 40) for 6-point Torx screws
- Machinist's hammer, 250 g
- Drift punch, 5 mm
- Tool for removing the handwheel from the valve and for removing housing screws from the gearboxes
- Screwlock (for example: Loctite)

Check the name plate and the key interlock sequence plan to make sure that the valve interlock is appropriate and intended for use with the valve prior to commencing installation tasks.

Clean the work environment by removing dirt, grease and oil.

10.2 General approach

Only use precisely fitting tools (spanners) for removing and tightening bolts and nuts. Otherwise bolts and nuts may become damaged and unusable.

Observe the acceptable tightening torques:

M4: 2.5 Nm

M5: 4 Nm

M6: 7 Nm

M8: 18 Nm

M10: 35 Nm

Use appropriate means to secure all threaded fittings for example Loctite. For application follow the instructions of the corresponding manufacturer.

10.3 Installation on standard valve

Open the valve all the way to be able to determine the spindle height.

Remove the standard handwheel fitted to the valve and all associated bolts, nuts and washers.

Check the valve spindle for damage. Remove any burrs, and smoothen sharp edges to avoid injuries and to be able to fit the adapter without any problem.

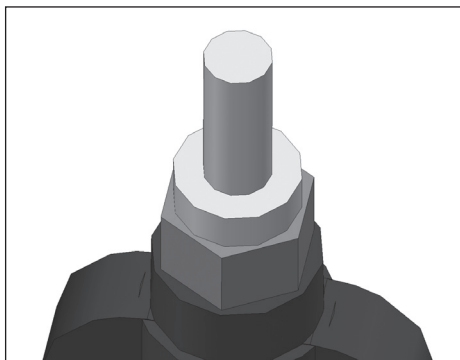

Position the adapter on the valve spindle. Keep in mind that the holes in the adapter are located on the valve side (smaller edge distance).

Use an appropriate washer and a nut to secure the adapter. You can use the original nut of the handwheel, unless it is damaged.

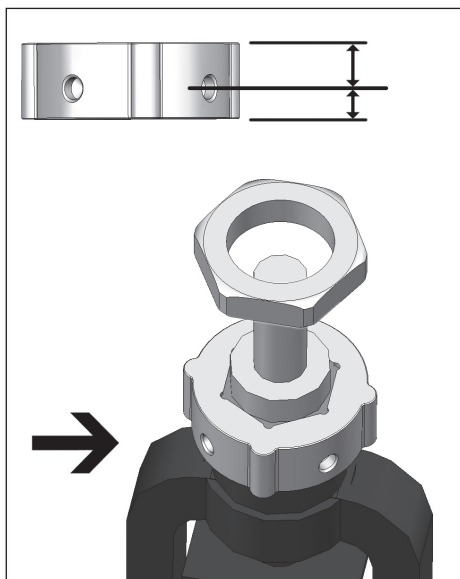

Screw the four threaded pins into the housing of the valve interlock until they are flush against the inside.

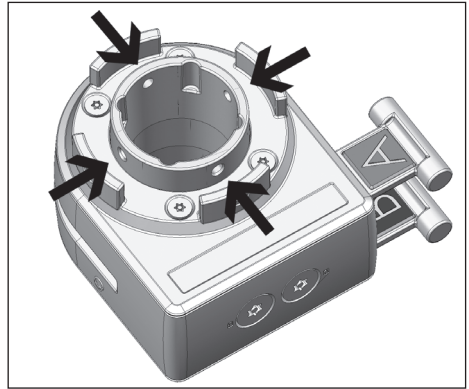

Align the valve interlock above the line so that the keys can be easily reached; four positions are possible.

Insert the torque support into the valve lock, so that it can be guided above the line later on. Punch in four slotted pins to secure the assembly. **Avoid damaging the valve with the hammer.**

Then fit the valve interlock with torque support on the adapter.

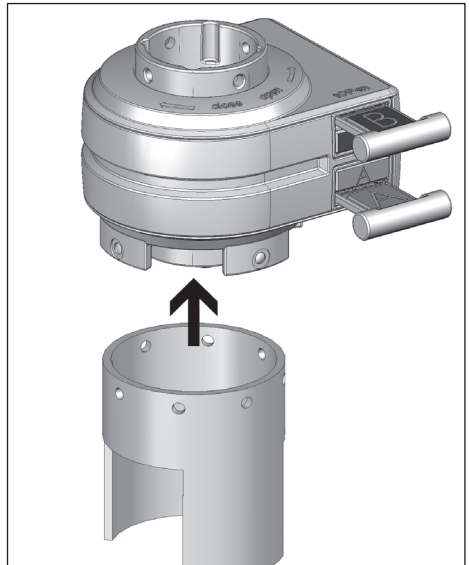

Screw two threaded pins through the holes in the torque support and tighten.

Use the four threaded pins to install the supplied handwheel. You can remove the cover of the handwheel if the valve spindle is very long.

Rotate the handwheel through 90° and screw the other two threaded pins through the holes in the torque support and tighten.

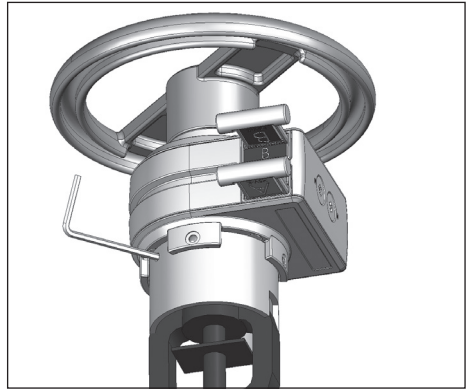

Make sure that the valve is opened all the way. Use the Tx 40 Torx key to completely remove the security screw on the right-hand side from the housing.

Use a 2 mm Allen key to tighten, through the opening, the two threaded pins which are located inside the housing.

Re-fit the security screw and tighten it using the Tx 40 Torx key.

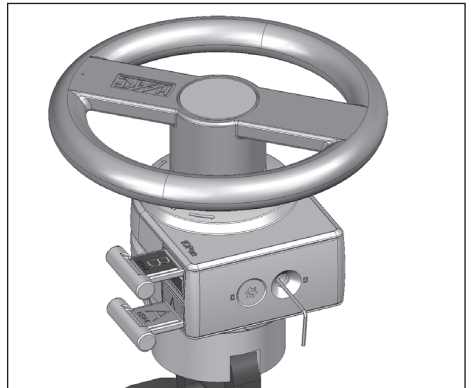

Close the valve and completely remove the security screw on the left-hand side from the housing using the Tx 40 Torx key.

Use a 2 mm Allen key to tighten, through the opening, the two threaded pins which are located inside the housing.

Re-fit the security screw and tighten it using the Tx 40 Torx key.

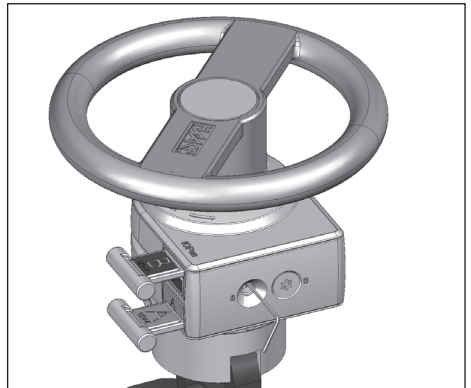

10.4 Installation on gearbox valve

Remove the standard handwheel fitted to the gearbox and all associated bolts, nuts and washers.

Check the gearbox spindle for damage. Remove any burrs, and smoothen sharp edges to avoid injuries and to be able to fit the adapter without any problem.

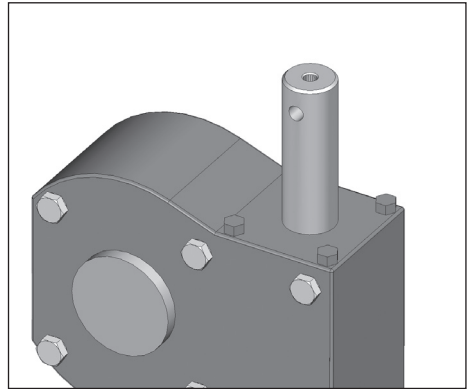

Slide the assembly bracket over the gearbox spindle in order to determine which screws of the gearbox housing need to be removed.

Completely unscrew the corresponding screws and remove these from the housing.

Correctly position the assembly bracket and tighten it using new and appropriately fitting security screws. Make sure that the screws are not too long so as to prevent them from protruding too deeply into the gearbox.

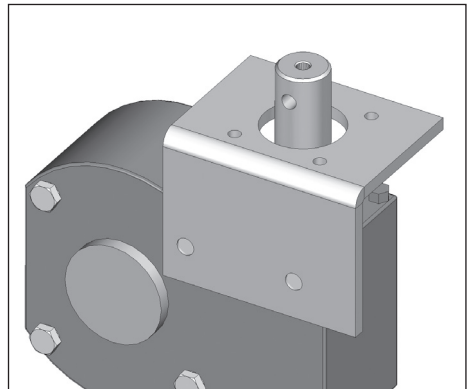

Fit the ISO shell on the gearbox spindle and tighten it using the four countersunk screws.

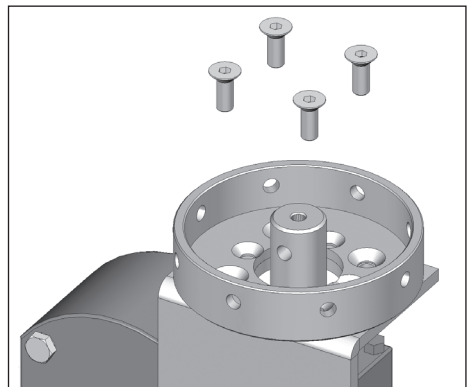

Fit the adapter on the gearbox spindle. Keep in mind that the holes in the adapter are located on the valve side (smaller edge distance).

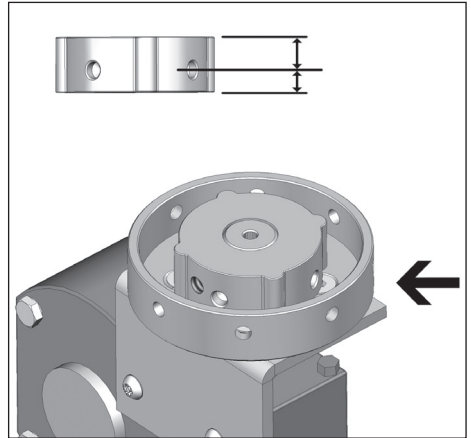

You may need to fix the adapter to the gearbox spindle in case of a shaft with transverse holes for example.

To this end, insert two threaded pins into the adapter and tighten the pins through the holes in the ISO shell.

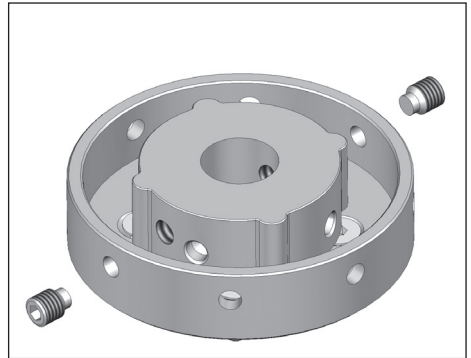

Fix the adapter to the valve interlock, if the adapter does not need to be fixed to the gearbox spindle.

Align the valve interlock so that the keys can be easily reached; four positions are possible.

Fit the valve interlock on the ISO shell and punch in the four slotted pins to secure the assembly. **Avoid damaging the valve with the hammer.**

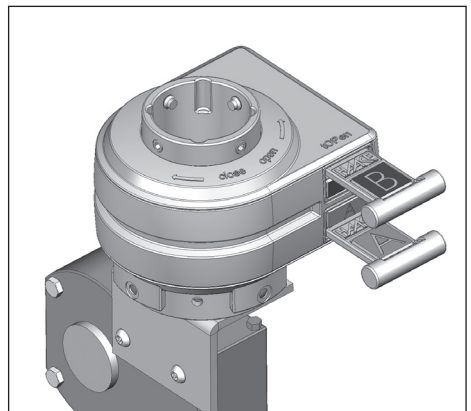

Use the four threaded pins to install the supplied handwheel. You can remove the cover of the handwheel if the valve spindle is very long.

Make sure that the valve is opened all the way. Use the Tx 40 Torx key to completely remove the security screw on the right-hand side from the housing.

Use a 2 mm Allen key to tighten, through the opening, the two threaded pins which are located inside the housing.

Re-fit the security screw and tighten it using the Tx 40 Torx key.

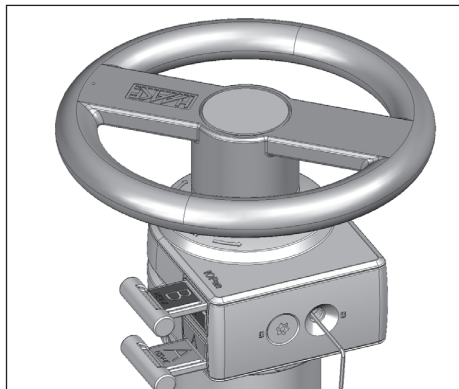

Close the valve and completely remove the security screw on the left-hand side from the housing using the Tx 40 Torx key.

Use a 2 mm Allen key to tighten, through the opening, the two threaded pins which are located inside the housing.

Re-fit the security screw and tighten it using the Tx 40 Torx key.

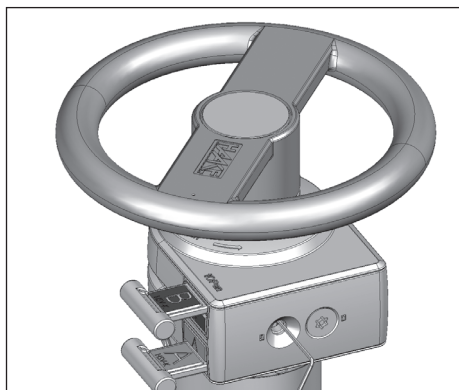

11 Performance check

Attention!

The protective effectiveness of the valve interlock is to be checked regularly within the scope of and in accordance with the German Ordinance on Industrial Safety and Health (Betriebssicherheitsverordnung). Once installed, do not loosen any bolts or nuts or remove any pins; otherwise, the effectiveness of the safety-related functions is no longer guaranteed.

Once finished with installation tasks, carry out the following inspections:

- Check all bolted connections for tightness and ensure that the bolts cannot come loose by themselves.
- Check whether the key(s) can be easily inserted and whether the key(s) only fit in one given shaft.
- Insert both keys and check the valve for ease of movement.
- Completely open the valve, remove the upper key and rotate the handwheel. It must not be possible to close the valve.
- Re-insert the upper key and close the valve.
- Remove the lower key and rotate the handwheel. It must not be possible to open the valve.
- Re-insert the lower key and partially open the valve.
- Check whether both keys are locked and that these keys cannot be removed.
- Record the results of performance check.

12 Operation

Attention!

Do not ever attempt to disengage the interlock in a locked state with an extended arm of a lever. This may destroy the inner components and disable the safety function.

Do not ever attempt to insert or remove a key by applying excessive force or with the aid of a tool (hammer).

Only actuate the valve if both keys have been completely inserted.

If the valve is closed, you can remove the lower key and if the valve is opened, the upper key can be removed.

- Insert the appropriate key into the open key shaft while slightly rotating the handwheel. The interlock is disengaged. With one complete revolution of the handwheel the key will be locked in the key shaft.
- Turn the handwheel all the way to the other end position (open or close).
- Remove the other key from the valve interlock and slightly rotate the handwheel until the lock snaps in place. Now the valve is locked and can no longer be actuated.

13 Maintenance

13.1 Readjusting the register

The end positions of the valve may be altered due to wear of the valve. This means that the number of handwheel revolutions needed to reach either end position will increase.

Hence, it may be necessary to adjust the register for one or both end positions.

- First return the valve to its former end position.
- Use the Tx 40 Torx key to completely remove the corresponding security screw from the housing.
- Use a 2 mm Allen key to loosen, through the opening, the two threaded pins which are located inside the housing and unscrew these by **only approximately 2 mm**.
- Continue to rotate the handwheel until it has reached the new end position.
- Use a 2 mm Allen key to re-tighten, through the opening, the two threaded pins which are located inside the housing.
- Re-fit the security screw and tighten it using the Tx 40 Torx key.
- Check the other end position and proceed as described above if required.

13.2 Checks

The valve interlock has been lubricated for life.

Attention!

Adapt the frequency of checks to the environmental conditions at the application site.

We recommend introducing the following measures within the scope of preventative maintenance:

- Check the valve interlock at regular intervals (at least once a year) for external damage.
- Cleaned a soiled valve interlock using neutral soap suds and a cloth.
- Check for signs of corrosion and check the valve interlock for proper working order as needed.

14 Disassembly

Disassembly procedures depend on the conditions at the site. Observe the following essential instructions:

Only use precisely fitting tools (spanners) for removing and tightening bolts and nuts. Otherwise bolts and nuts may become damaged and unusable.

With the torque support mounted, rotate the handwheel through 45° in order to reach the bolts in the adapter.

Carefully loosen all bolts/screws. It may be necessary to drill out stuck bolts/screws.

Only remove the complete valve interlock assembly and then install a standard handwheel. Do not dismantle the valve interlock assembly on your own.

15 Troubleshooting

Fault	Possible cause	Remedy
You cannot remove the key.	End position not reached	Make sure the valve is at one of its end positions.
	The other key is not completely inserted.	Insert key right up to the stop.
	End position has been set incorrectly.	Remove the security screws from the side of the housing. You should now see both threaded pins in their corresponding end positions on the inside of the housing. Unless this is the case, loosen the threaded pins and re-adjust their end positions (see section on Installation).
You cannot insert the key.	Wrong key.	Check identification of key and key shaft.
	Valve blocks the interlock.	Slightly rotate the handwheel when inserting the key.
	Foreign matter in the key shaft.	Carefully remove foreign matter. If this is not possible, contact Haake Technik.
	Formation of ice.	Slightly warm up the valve interlock. Do not use excessive heat!
	Deformed key.	Check key. Contact Haake Technik in case of deformation.
Unable to install the valve interlock.	Wrong position.	Check valve and name plate against key interlock sequence plan.
	Faulty valve information (for example: new version).	Contact Haake Technik.
Unable to remove the valve interlock.	Screws/Bolts secured very firmly.	Contact Haake Technik.
Valve interlock does not disengage.	Key has not been correctly inserted.	Insert key right up to the stop.

Fault	Possible cause	Remedy
Valve interlock does not lock.	Lock lever not hooked.	After removal of key, slightly rotate the handwheel until the valve interlock locks into place.
Logic circuit not safe.		Check key interlock sequence plan; check installation; contact Haake Technik.
Valve can only be actuated with great difficulty.	Valve does not move smoothly.	Remove valve interlock and actuate the valve. Lubricate the valve if necessary.
	Valve interlock does not move smoothly.	Contact Haake Technik.
Lost keys.		Contact Haake Technik.

16 Technical data

Material	316 stainless steel
Ambient temperature	-40 to +80 °C
Application areas	Water supply networks, power plants, oil and gas networks, tank farms, bottling plants, paper mills
Application environment	Outside/Inside
Ambient atmosphere	Industrial environment
Vibration resistance	10 to 55 Hz
Impact resistance	max. 30 g
Mechanical life	10,000 actuations MTTF _d 150 years
Service life	30 years
Position of use/ Installation position	Horizontal/Vertical
Fastening	On valve drive element
Weight	HSV-S-R: 3 to 5 kg (dependent on handwheel torque support) HSV-M-R: 6 to 8 kg (dependent on handwheel and torque support) HSV-L-R: 8 to 12 kg (dependent on handwheel and torque support)
Holding force	HSV-S-R: 125 Nm HSV-M-R: 250 Nm HSV-L-R: 500 Nm
Year of manufacture	2010

17 Dimensions

HSV-S-R

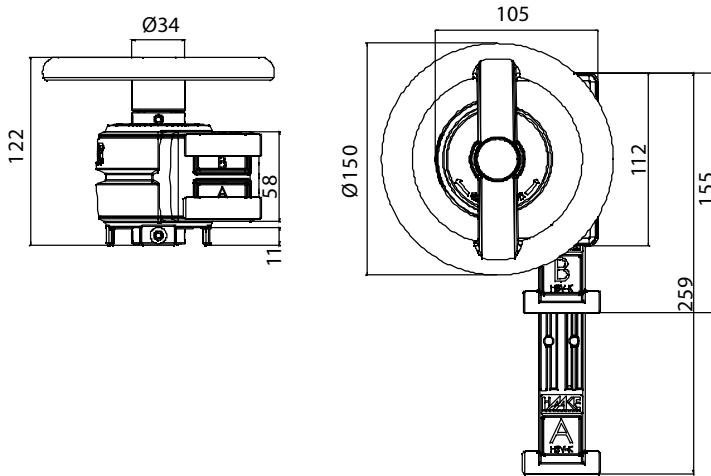

HSV-M-R

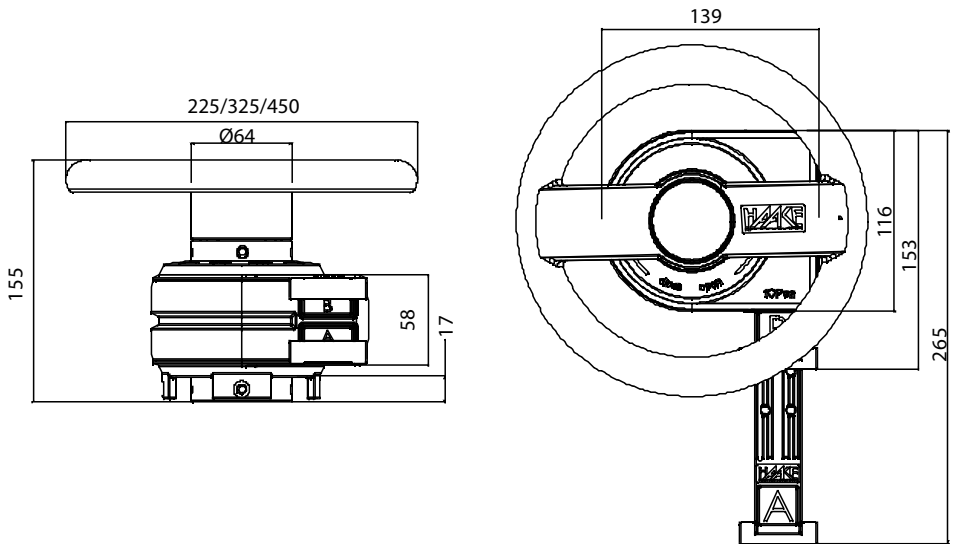

Dimensional specifications in mm.

HSV-L-R

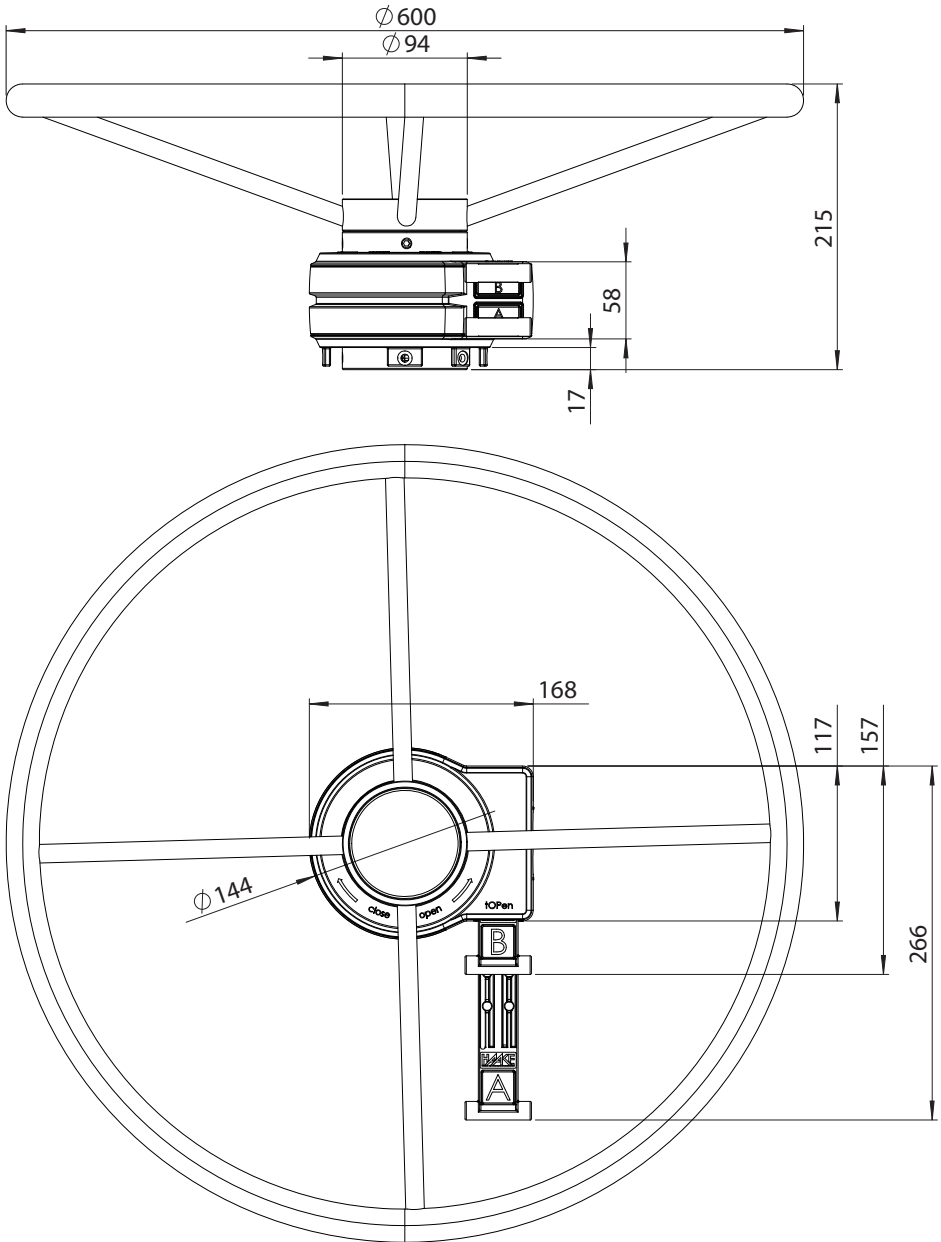

Dimensional specifications in mm.

18 EC Declaration of Conformity

EC Declaration of Conformity in accordance with EC Directive 2006/42/EC, Annex II A

The company **Haake Technik GmbH**
Master Esch 72
D-48691 Vreden, Germany

hereby declares that the
safety component: **Safety valve interlock
for handwheel-operated valves**

Type: **HSV-L-R-2, HSV-M-R-2, HSV-S-R-2
HSV-L-R-10, HSV-M-R-10, HSV-S-R-10
HSV-L-R-1C, HSV-M-R-1C, HSV-S-R-1C
HSV-L-R-2C, HSV-L-R-20, HSV-M-R-2C, HSV-M-
R-20, HSV-S-R-2C, HSV-S-R-20
HSV-L-R-1C1F, HSV-M-R-1C1F, HSV-S-R-1C1F
HSV-L-R-2-cc, HSV-M-R-2-cc, HSV-S-R-2-cc
HSV-L-R-1C-cc, HSV-M-R-1C-cc, HSV-S-R-1C-cc
HSV-L-R-1C1F-cc, HSV-M-R-1C1F-cc, HSV-S-R-
1C1F-cc**

Serial number: **as indicated on the product**

in its delivered form complies with the following relevant provisions:

EC Directive: **Machinery Directive 2006/42/EC**

Test Specification: **GS-ET 31**

The above-mentioned safety component serves the purpose of locking handwheel-operated valves such as slide valves, cone valves, or valve end positions for gearboxes, and releasing the respective key.

Our quality management system guarantees that all safety components are manufactured to the same quality.

Consequently, the issued declaration of conformity applies to all produced safety components of the aforementioned type starting with the serial number 1132246.

The authorised representative responsible for the compilation of the technical documents is:

HAAKE Technik GmbH
Mr Jens Schoppen
Master Esch 72
D-48691 Vreden, Germany

Vreden, 31.08.10



André Haake
(Managing Director)

HAAKE Technik GmbH, Master Esch 72, D-48691 Vreden, Germany
Telephone: +49 2564 39650 Fax: +49 2564 396590

KE-K-HSV-R eng, Rev B, 13.12.10, jso.doc

